

Electromechanical Lubricant Distributor ESV-8

Technical Datasheet (Article 215227)

Product description

The ESV-8 electromechanical distributor offers a flexible way of lubricant distribution. The lubricant (oil and grease can be distributed) is conveyed to the inlet of the ESV-8 and can be passed through from there to any outlet.

The built-in control system allows the pistons at each outlet to be opened and closed mechanically independently. This allows the lubricant to be directed to the lubrication points where it is needed, as needed.

Built-in check valves in the outlets prevent the distributor from being affected by back pressure from the lubrication point. This provides high precision metering to the individual lubrication points.

The ESV-8 is thus an electronically controlled and monitored valve terminal for grease and oil. The lubricant itself is only directed through open channels and is not used as a pressure medium. Clogging by aged grease, solid lubricant particles such as graphite / Teflon or similar in the lubricant can thus be excluded. The ESV-8 thus exhibits high reliability in addition to its extreme flexibility.

The flow to the individual lubrication points can be controlled completely freely by the electronics and can be changed flexibly at any time.

The power supply (24 VDC) and the control of the electronics built into the ESV-8 can be done from a PLC. The communication between the ESV-8 and the PLC is done with an easy to program command and response protocol.

Intended use

The ESV-8 electromechanical distributor is designed for distribution of lubricant from one inlet to 1 to 8 independently selectable outlets.

The electronics ensure that only one outlet is open at a time. For the operation of the ESV-8 only one outlet is open at any one time. For the operation of the ESV-8 only the supply with 24 VDC is provided.

Important notes

To ensure trouble-free operation of the ESV-8, only the original accessories should be used.

Due to possible high pressures occurring when conveying grease through the ESV-8, special attention must be paid to the pressure resistance of the hose connections and hoses.

A detailed description of the function and electrical control of the ESV-8 by means of a control program is contained in the valid operating instructions.



Fig. 1: Elektromechanical lubricant distributor ESV-8

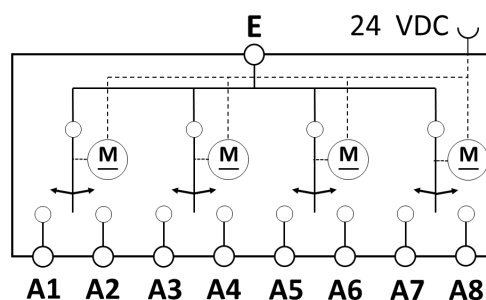

Fig. 2: Block diagram ESV-8

Technical data

Number of inlets	1
Lubricant inlet	Thread M 6 metric
Number of outlets	1 ... 8
Lubricant outlets	Thread M 10x1 metric
Medium	Oil up to 30.000 cSt (40°C)
	Grease up to NLGI - class 3
Operating temperature	min. - 4 °F
	max. +158 °F
max. back pressure	2900 psi
max. volume flow	60 cm ³ /min
Protection class	IP 54
Elektrical connection	M 12x1 4 - Pin connector
Power supply	24 VDC +/-10%
max. current during operation	0,2 A
Mounting position	any
Dimension	115mm x 83mm x 62mm
Weight	appr. 3,2 pounds

Important notes

The mechanical mounting of the ESV-8 can be done on two different surfaces of the housing. Three M5 screws are required in each case, one fixes the initial element and the other two fix the end element of the ESV-8. Figure 3 shows the holes for the fixing screws.

Hydraulic connection

The connection of the lubricant lines is also shown in Fig. 3. The inlet connection „LUB IN“ is connected to the supply line from the lubricant pump. The respective outlets (marked 1 ... 8 - see Fig. 3) are connected to the lubrication points provided for this purpose. It is essential to ensure correct assignment; the labels indicate the assignment of the outlets!

Electrical connection

The electrical connection of the ESV-8 is made with a 4-pole cable (unshielded is sufficient) with an M12x1 socket. The socket is screwed onto the connector in the ESV-8 (see Fig. 3) in a loss-proof and sealed manner.

The pin assignment of the M12x1 connector is A-coding, see Figure 4.

- PIN 1 Input voltage +24 VDC +/-10%.
- PIN 2 Control of the distributor (HIGH +24 VDC)
- PIN 3 Ground (GND)
- PIN 4 Output signal 24 VDC, short circuit proof
max. current carrying capacity 0.1 A, no inductive load

Control / Communication B10

The communication between a PLC / controller and the ESV-8 is realized by a simple digital protocol. The name of this communication protocol is B10 and can also be used by the FlexxPump for communication.

A small number of commands can be transmitted to the ESV-8 (see table), the ESV-8 responds immediately with a defined number of high pulses. The pulses have a precisely defined duration of 0.1s, with the pause times also being 0.1s. By counting the high edges, the PLC can immediately register the corresponding response. The graphical representation in Fig. 5 is intended to clarify this protocol.

Command	Pulse length	Answer	Impulses
Open A1	tB = 0,1 s	A1 opened	1
Open A2	tB = 0,2 s	A2 opened	2
Open A3	tB = 0,3 s	A3 opened	3
Open A4	tB = 0,4 s	A4 opened	4
Open A5	tB = 0,5 s	A5 opened	5
Open A6	tB = 0,6 s	A6 opened	6
Open A7	tB = 0,7 s	A7 opened	7
Open A8	tB = 0,8 s	A8 opened	8
Close	tB = 1,3 s	A1...A8 closed	21
Identification	tB = 1,4 s	„ID number“	19
Reference run	tB = 1,5 s	ok, done	13
PING	tB = 1,6 s	last command	change
Delete error	tB = 1,7 s	ok	17
		Error ESV-8	15

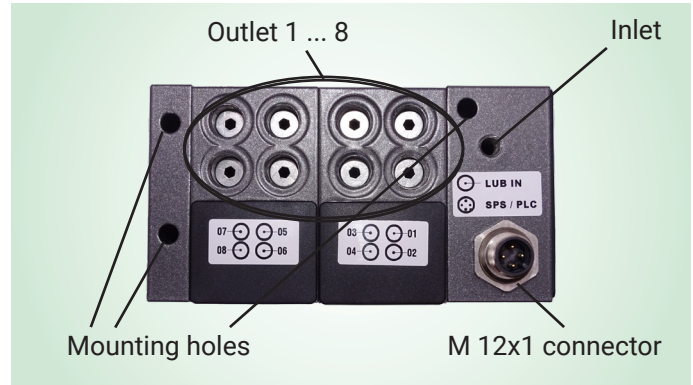

Fig. 3: Top view ESV-8

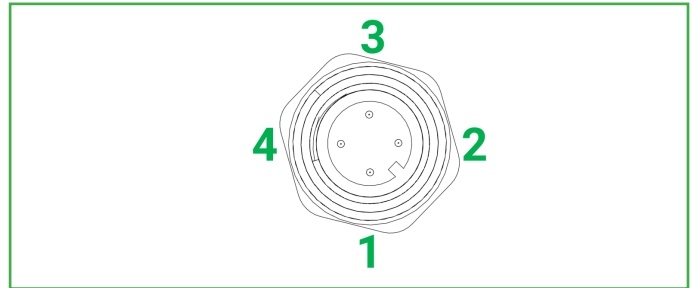

Fig. 4: Pin position of M12 connector

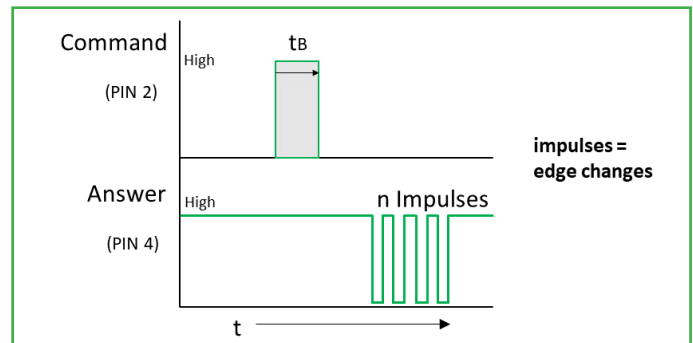

Fig. 5: Communication between PLC and ESV-8

LED-signals ESV-8

The ESV-8 signals the respective operating status through the side housing cover (Fig. 6). The following mean:

- no LED: OFF
- green LED: on - status ok green flashing: adjustment
- blue LED: communication
- red LED: error



Fig. 6: LED-signals on side

Application example of the ESV-8 for robot lubrication

Technische Daten FlexxPump4 D211	
Anzahl der Auslässe	1
Fördermenge / Hub	0,15 ml
Kartuscheninhalt	250 ml
Fördermedium	Fett FG2
Betriebsspannung	24 VDC
max. Stromaufnahme	0,3 A
max. Druckaufbau	70 bar
Temperaturbereich	-20°C...+70°C

The individual axes (x, y, z) are sometimes operated in significantly different ways and have different running times. As a result, the guide carriages of the axes also require significantly different relubrication quantities of grease. In contrast, the lubricating gear wheel of a toothed rack requires larger quantities of grease at shorter intervals compared to the guide carriages. The solution to the problem of the different lubrication intervals is very easy with a demand-oriented control of the ESV-8 by a PLC.

Outlets of the ESV-8 at the Z-axis which are not needed are not controlled, they can be closed. The interconnection of the inputs of the two ESV-8 is possible with a Y-piece.

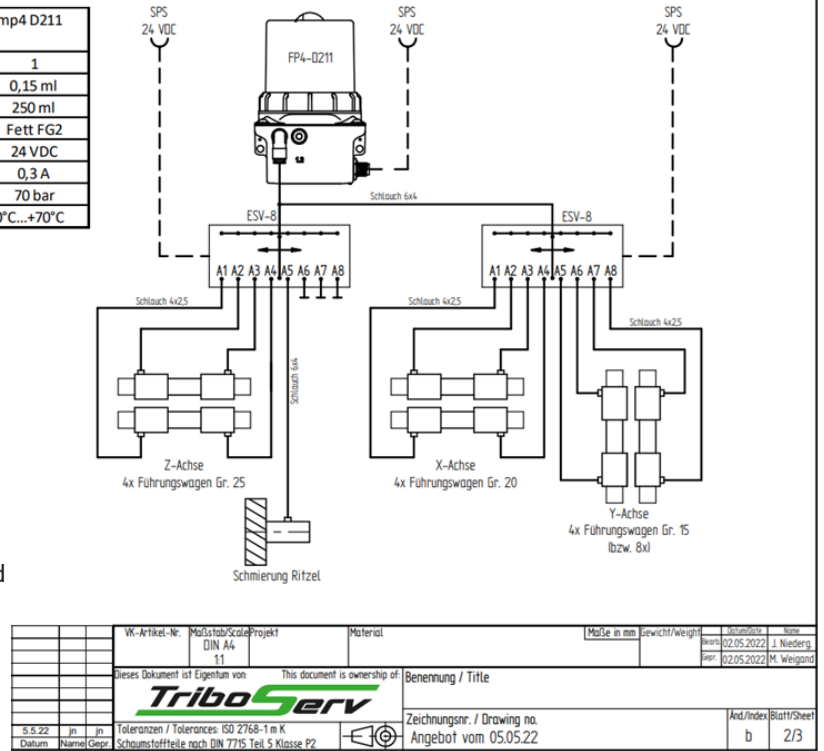

Fig. 7: Lubrication schedule of a robotic

Accessories and other ESV types

The ESV electromechanical lubricant distributor has a modular design. This modular design offers a further advantage: other ESV's with a different number of outlets are available. Figure 9 shows the ESV-4, ESV-8 and ESV-12. Due to this variety, a favorable solution can always be achieved in different applications. For the best possible support of the movable hoses at the outlets of the ESV, a special angle plate with hose nozzles can be used (Fig. 8). This ensures mechanical stability of the hose connection parts and thus maximum safety over a long period of time.



Fig. 9: Different types of ESV: ESV-4, ESV-8 and ESV-12

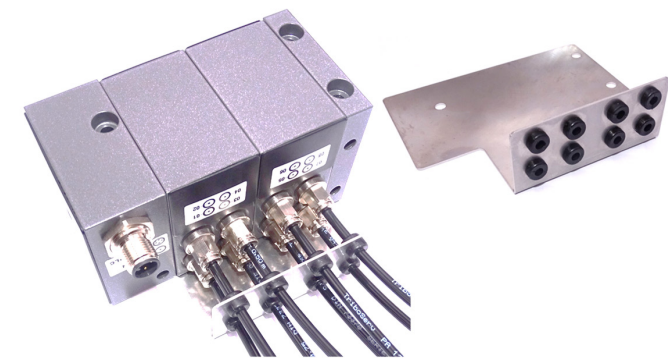

Fig. 8: Tube fixing with metal sheet

In addition to this useful angle are of course many other accessories such as:

- Hose connection parts for 4, 6 and 8 mm diameter Hoses (unfilled and prefilled)
- Cable 4-pole with molded socket M12x1
- Pumps for lubricant supply (FlexxPump)
- Progressive distributor as sub-distributor
- Greases in cartridges and oils and much more ...

are available for the implementation of a complete application. Ask us, we are happy to support you!

The above data and information correspond to the state of knowledge and development valid on the date of preparation. However, they do not represent any assurance of properties or a guarantee for the suitability of the products in individual cases. TriboServ reserves the right to change the information in this technical data sheet at any time and without prior notice or to make technical changes that do not affect the quality of the product. The representations in the pictures may differ from the original picture of the product.



TriboServ GmbH & Co. KG
 Persönlich haftende Gesellschaft: TriboServ Verwaltungs GmbH
 Geschäftsführung: Dr.-Ing. Michael Weigand



Gelthari-Ring 3 – 97505 Geldersheim – Deutschland

Telefon: +49 (0) 9721 47396 60
 Telefax: +49 (0) 9721 47396 69
 Mail: info@triboserv.de
 Web: www.triboserv.de



© 2022

Version E1.0
 Sheet 3 of 3