

FlexxPump1 N125A

Technical data sheet (Item number 208010)

Product Description

The FlexxPump1 N125A (FP1 N125A) is a highly efficient, microprocessor-controlled single point lubricator designed for a need-based direct supply of a lubrication point with grease or highly viscous oil.

Various operating modes are available. In the hour mode (-h), pause times as well as a number of dispensing strokes can be set. In the emptying time mode (Et), an emptying time of the cartridge can be set in months. The "pulse mode" (PUL) allows external control of the FP1 N125A.

The lubrication intervals and lubricant delivery rates can be individually controlled directly on the FP1 N125A or a PLC.

The display of the FP1 N125A or an external connection to a PLC enables crucial status monitoring such as empty level, proper running, back pressure of the lubrication point and error messages. The Integrated controller of the FP1 N125A detects when the cartridge is empty and sends a unique warning signal to the external controller.

The FP1 N125A can be powered by an external power adapter or 24VDC from the external controller.

Pre-filled lubricant cartridges are available as accessories.

Intended Use

Intended use of the FP1 N125A is to supply a single lubrication point with grease or highly viscous oil.

Technical Data

Power supply		+24 VDC +/-10%
Number of outlets		1
Operating temperature	min.	- 20 °C
	max.	+ 60 °C
Maximum output pressure		50 bar (725 psi)
Protection class		IP 54
Volume per dispensing stroke		0,15 ml
Lubricants	Grease	up to NLGI Class 2
	Oil	up to 30,000 mm ² /s (40 °C)
Cartridge volume		125 ml
Outlet connection		External thread M16x1,5 Internal thread M10x1
Mounting position		upright
Weight (without cartridge)		365 g

Important instructions

To ensure trouble-free operation on the FP1 N125A, do not disassemble the unit. To prevent damage to the electronics, only original battery packs must be used.

A detailed description of the operation and control of the FP1 N125A is available in the up-to-date user manual!



Figure 1: FP1 N125A front view



Figure 2: FP1 N125A drive unit

Electrical Connection

Connector Type	M12x1, 4-pole, A-coding
Pin assignments	PIN 1 Input +24 VDC +/- 10% max. current consumption 0,3 A
	PIN 2 Pump control +24VDC +/- 10%
	PIN 3 Ground (GND)
V Output Signal = V Input Signal	PIN 4 Output signal, +24 VDC +/- 10% max. current capacity 0,1 A, short-circuit protected, No inductive load

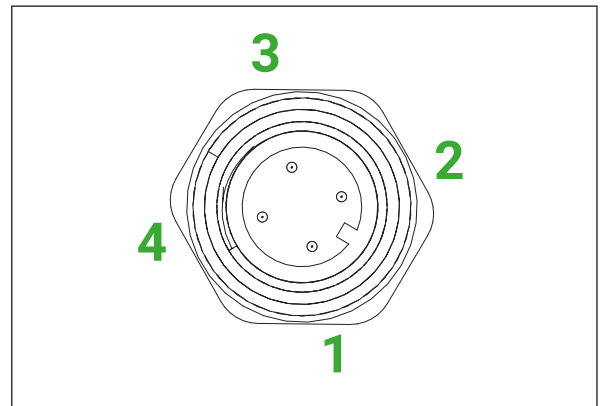

Operating mode Hour mode (-h-)

The hour mode -h- allows setting the number of dispensing strokes (c) and a pause time (h) between two dispensing cycles in hours. Pause times (h) between 1...99 hour(s) and the number of dispensing strokes (c) between 1...10 can be set. Therefore, a dispensing cycle consists of up to 10 dispensing strokes. The FP1 N125A delivers the set number of dispensing strokes during the pause time.

Default settings Hour mode (-h-)

Pause time: h = 6 hours
Number of strokes: c = 1

Operating mode Emptying time (Et)

The emptying time mode Et allows the emptying time of the cartridge to be set in months. Emptying times between 1...24 month(s) can be set. The FP1 N125A calculates a pause time and delivers a dispensing stroke after the pause time has elapsed.

Default settings Emptying time (Et)

Emptying time: Et = 6 months

Display – Meaning of LEDs

LCD	Explanation
	The red LED flashes every 5 seconds if there is an error.
	The yellow LED lights up when the action area has been touched with the magnetic pen (magnetic pen detected).
	The green LED lights up for approx. 10 ... 18 seconds during a dispensing process.
	The green LED flashes every 5 seconds if the FP1 N125A is switched on (ON) and there is no error.

Commands for control

The commands explained below can be called up at any time in operating mode -h- and in operating mode Et.

Command	Explanation
INF	The INF command provides an informative overview of the current settings on the FP1 N125A.
SET	The SET command allows you to make changes to the operating mode.
RUN	The RUN command enables a single dispensing to be triggered manually on the FP1 N125A.
PRO	The PRO command allows you to make changes to the settings and dispensing action of the FP1 N125A.
FIL	The FIL command allows you to manually trigger 40 dispensing action of the FP1 N125A.

Error messages on the display

Error messages	Meaning
E1	Error E1 (empty cartridge)
E2	Error E2 (overload)
E3	Error E3 (undervoltage)
E4	Error E4 (internal device error)

Operating mode Pulse mode (PUL)

In the pulse mode PUL, the FP1 N125A can be operated and controlled by an external control system such as a PLC unit. The FP1 N125A ensures the delivery of one or more dispensing stroke(s) depending on the control signals from the external controller.

Control via PIN 2

Software version	N11
Signal length 2s	1 delivery stroke
Signal length 12s	40 delivery strokes
Signal length 14s	Acknowledgment of errors, interruption of the lubricant delivery

Output Signals at PIN 4

Operation readiness – HIGH level

The FP1 N125A sends a permanent output signal (HIGH level) to PIN 4, which indicates that it is ready for operation. The output signal at PIN 4 can be tapped for further processing (e.g., LED or as a level for an external control).

Feedback Signal (only in PUL mode)

After successful activation, the FP1 N125A sends a LOW level output signal to the external controller as confirmation for the duration of the motor running (ML). After the end of an error-free dispensing stroke, the output signal on the FP1 N125A changes back to a HIGH level.

Error Signal – LOW level

If there is an error, the FP1 N125A sends continuous LOW level output signal for more than 30s at PIN 4. This is not the error signal for an empty cartridge!

Empty Cartridge Signal – Square wave signal, $f = 0,5 \text{ Hz}$

The FP1 N125A is equipped with a sensor that determine when the lubricant cartridge is empty. The empty cartridge report is transmitted to the external controller. A separate, unique output signal is provided which can be easily recognized by the external controller.

Hint Pulse mode (PUL)

Make sure that your control program is correctly selected for your application and that the lubrication point is supplied with the right amount of lubricant per unit of time.

Example: Control signal 2 seconds

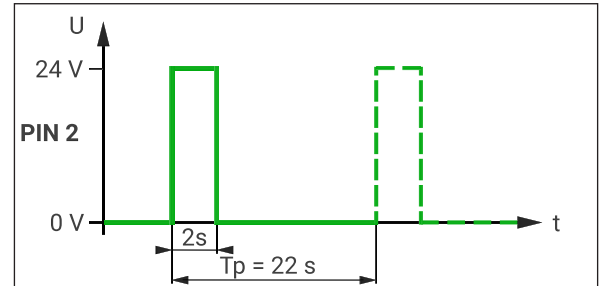

T_p = pause time between two control signals (see user manual for description)

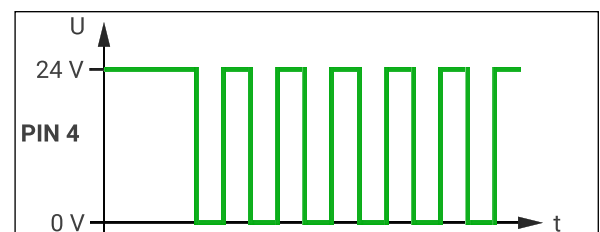
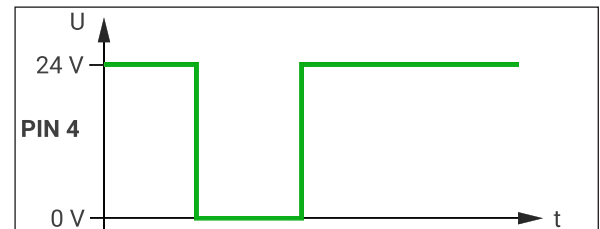
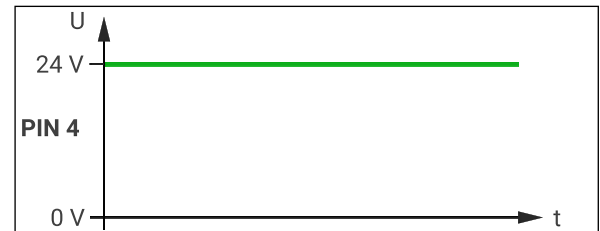

Installation dimensions

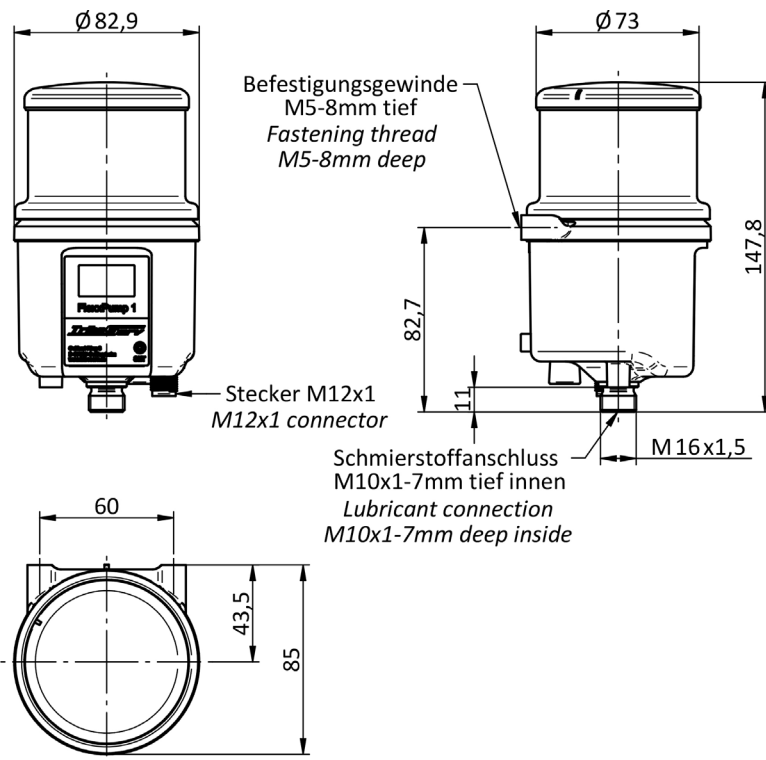

Installation

When installing, allow a minimum of 176 mm clearance from the top of the pump in opening direction of the cartridge for easy replacement.

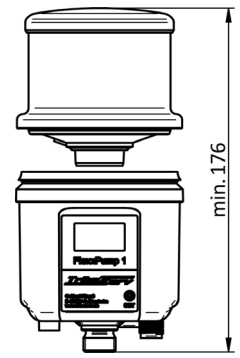

Materials

Housing of drive unit	Polyamide 6, glass fiber reinforced
Thread inserts	Brass
Drive unit cover	Polyamide 6.6, glass fiber reinforced
Grease cartridge	Polypropylene, Polyethylene
Threaded connector	Stainless steel

Similar products

Description	Difference	Item-Nr.
FlexxPump1 N125	Drive unit cover green	210998
FlexxPump1 N250	Cartridge 250 ml, Drive unit cover green	210999
FlexxPump1 N250A	Cartridge 250 ml, Drive unit cover anthracite	210770



Figure 3: FP1 N125A back

Please visit www.triboserv.com for available Accessories

The above data and information correspond to the current state of our knowledge and development. However, they do not represent an assurance of properties or a guarantee for the suitability of the products in individual cases. We reserve the right to change the information in this technical data sheet or to make technical changes at any time and without prior notice. The representation on the pictures may differ from the original.

TriboServ

SpectroLube Inc.
President: Aykut Ozdemir

2212 Silverbirch Court
L7M 3H4 Burlington, Ontario
Canada

Phone: +1 (647) 278-4366
Mail: aykut.ozdemir@spectrolube.com
Web: www.spectrolube.com



Quality Management

We are certified.

ISO 9001:2015

© – 2021

EN
Version: 1.0
Page 4 of 4