

FlexxPump4 D222A

Technical data sheet (Item number 210945)

Product Description

The FlexxPump4 D222A (FP4 D222A) is a highly efficient, microprocessor-controlled single point lubricator designed for a need-based direct supply of two lubrication points with grease or highly viscous oil.

The lubrication intervals and lubricant delivery rates can be individually controlled directly on the FP4 D222A or with a PLC. The lubricating pulse (control signal) generated by a controller is transmitted to the FP4 D222A via a 4-core connection cable (available as an accessory). The connection also enables crucial condition monitoring of the FP4 D222A by the control system such as level pre-warning, level empty, back pressure and proper functioning message.

The Integrated controller of the FP4 D222A detects when the cartridge is empty and sends a unique warning signal to the external controller.

The FP4 D222A can be powered by an external power adapter or 24VDC from the external controller.

Pre-filled lubricant cartridges are available as accessories.

Intended Use

Intended use of the FP4 D222A is to supply two lubrication points with grease or highly viscous oil.

Technical Data

Power supply	+24 VDC +/-10%	
Number of outlets	2	
Operating temperature	min.	-20 °C
	max.	+60 °C
Maximum output pressure	70 bar	
Protection class	IP 54	
Volume per dispensing stroke	0,15 ml	
Lubricants	Grease	up to NLGI Class 2
	Oil	up to 30.000 mm ² /s (40°C)
Cartridge volume	250 ml	
Outlet connection	Connector for hose 6 mm	
Mounting position	any	
Weight (without cartridge)	1400 g	

Important instructions

To ensure trouble-free operation on the FP4 D222A, do not disassemble the unit. To prevent damage to the electronics, only original battery packs must be used.

A detailed description of the operation and control of the FP4 D222A is available in the up-to-date user manual!

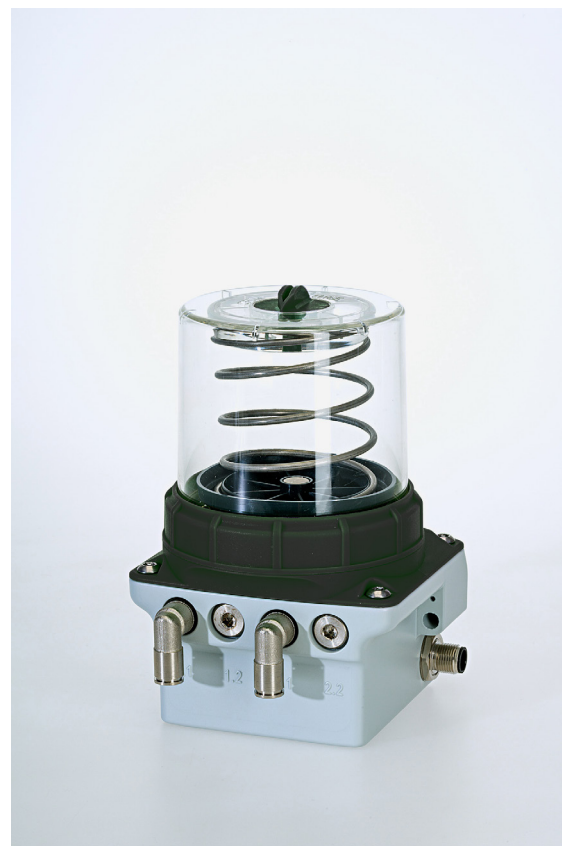

Figure 1: FP4 D222A front view



Figure 2: FP4 D222A with 250 ml

Electrical connection

Connector Type	M12x1, 4-pole, A-coding
Pin assignments	PIN 1 Input +24 VDC +/- 10% max. current consumption 0,3 A
	PIN 2 Pump control +24VDC +/- 10%
	PIN 3 Ground (GND)
V Output Signal = V Input Signal	PIN 4 Output signal, +24 VDC +/- 10% max. current capacity 0,1 A, short-circuit protected, No inductive load

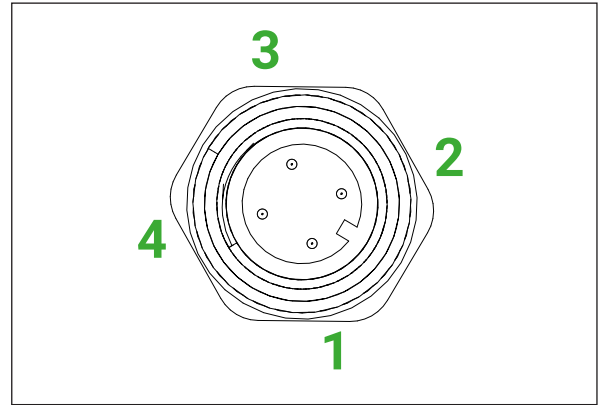

Control via PIN 2

Software Version	D42
Signal length 2s	1 Dispensing stroke PB1 (1.1 or 1.2)
Signal length 5s	1 Dispensing stroke PB2 (2.1 or 2.2)
Signal length 8s	2 Dispensing strokes (1x PB1 + PB2)
Signal length 12s	40 + 40 Dispensing strokes (PB1+PB2)
Signal length 14s	Acknowledgement of errors, interruption of lubricant supply

PB = Pump body

Output Signals at PIN 4

Operational readiness – HIGH level

The FP4 D222A sends a permanent output signal (HIGH level) to PIN 4, which indicates that it is ready for operation. The output signal at PIN 4 can be tapped for further processing (e.g., LED or as a level for an external control).

Feedback Signal / Level pre-warning signal

After successful activation, the FP4 D222A sends a LOW level output signal to the external controller as confirmation for the duration of the motor running (ML). After the end of an error-free dispensing stroke, the output signal on the FP4 D222A changes back to a HIGH level. If the filling level of the cartridge falls below approx. 75 cm³, the pump control extends the LOW level to 17s regardless of the engine running. This signal is defined as a pre-warning signal (VWS) for predictive level monitoring.

Error Signal – LOW level

If there is an error, the FP4 D222A sends continuous LOW level output signal for more than 30s at PIN 4. This is not the error signal for an empty cartridge!

Empty Cartridge Signal – Square wave signal, f = 0,5 Hz

The FP4 D222A is equipped with a sensor that determine when the lubricant cartridge is empty. The empty cartridge report is transmitted to the external controller. A separate, unique output signal is provided which can be easily recognized by the external controller.

Example: Control signal 2 seconds

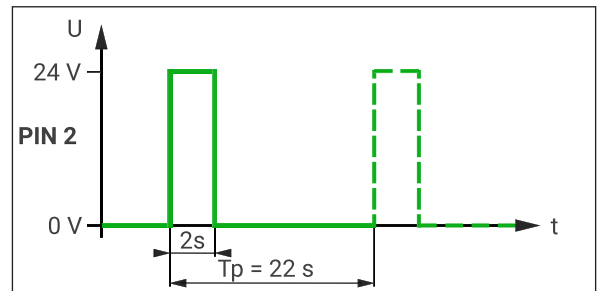

Tp = pause time between two control signals (see user manual for description)

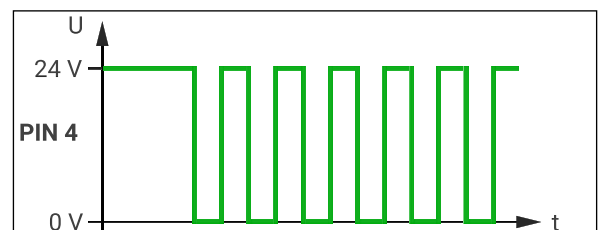
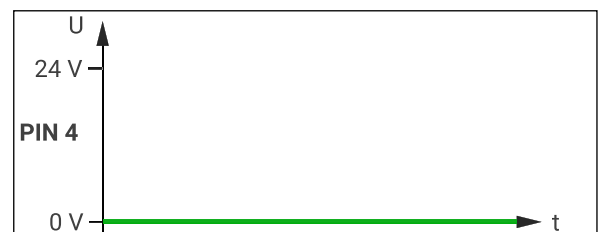
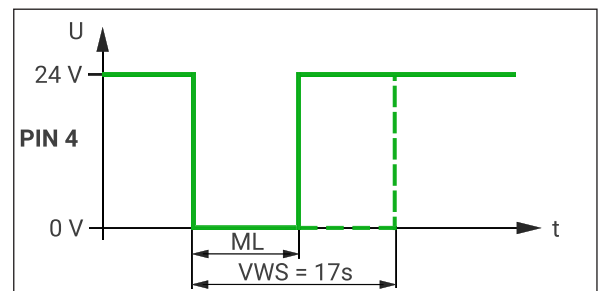
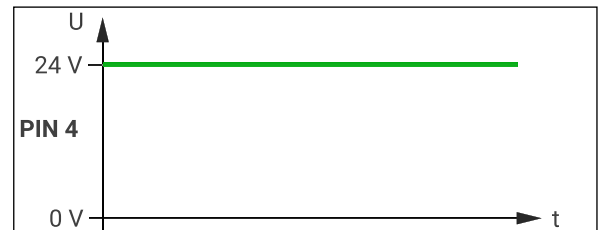

Installation dimensions

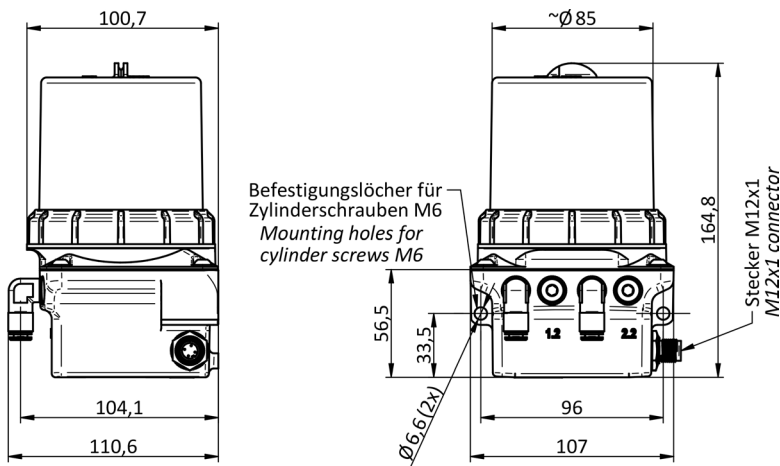

Installation

When installing, allow a minimum of 340 mm clearance from the top of the pump in opening direction of the cartridge for easy replacement.

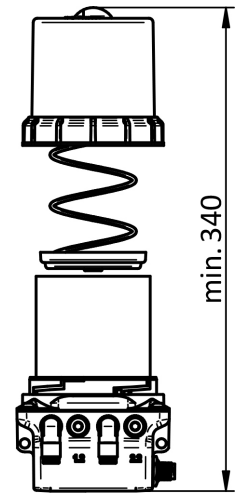

Materials

Housing of drive unit	Die-cast zinc, powder-coated
Transparent top	Polyamide (impact-resistant, lubricant-resistant, UV-stable)
Drive unit cover	Polyamide 6.6, glass fiber reinforced
Screws	Stainless steel A2
Hose connector	Brass, nickel-plated
Grease cartridge	Polypropylene, polyethylene
Compression plate	Polyamide 6.6 (impact-resistant, lubricant-resistant)
Compression spring	Stainless spring steel

Similar products

Description	Difference	Item-Nr.
FlexxPump4 D222	Drive unit cover green	210940
FlexxPump4 D422-OIL	Oil as lubricant, green	210950
FlexxPump4 D422A-OIL	Oil as lubricant, anthracite	210955
FlexxPump4 D422	Cartridge 400 ml, green	210930
FlexxPump4 D422A	Cartridge 400 ml, anthracite	210935

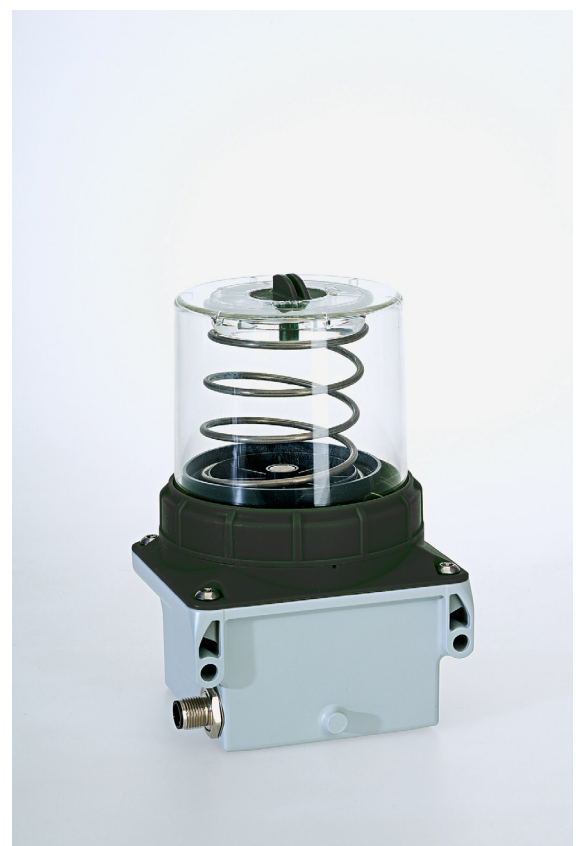

Figure 3: FP4 D222A back

Please visit www.triboserv.com for available Accessories

The above data and information correspond to the current state of our knowledge and development. However, they do not represent an assurance of properties or a guarantee for the suitability of the products in individual cases. We reserve the right to change the information in this technical data sheet or to make technical changes at any time and without prior notice. The representation on the pictures may differ from the original.

TriboServ

SpectroLube Inc.
President: Aykut Ozdemir

2212 Silverbirch Court
L7M 3H4 Burlington, Ontario
Canada

Phone: +1 (647) 278-4366
Mail: aykut.ozdemir@spectrolube.com
Web: www.spectrolube.com



Quality Management

We are certified.

ISO 9001:2015

© – 2021

EN
Version: 1.0
Page 3 of 3