

FlexxPump4 N411A

Technical data sheet (Item number 210960)

Product Description

The FlexxPump4 N411A (FP4 N411A) is a highly efficient, microprocessor-controlled single point lubricator designed for a need-based direct supply of a lubrication point with grease or highly viscous oil.

The lubrication intervals and lubricant delivery rates can be individually controlled directly on the FP4 N411A or with a PLC. The lubricating pulse (control signal) generated by a controller is transmitted to the FP4 N411A via a 4-core connection cable (available as an accessory). The connection also enables crucial condition monitoring of the FP4 N411A by the control system such as level pre-warning, level empty, back pressure and proper functioning message.

The Integrated controller of the FP4 N411A detects when the cartridge is empty and sends a unique warning signal to the external controller.

The FP4 N411A can be powered by an external power adapter or 24VDC from the external controller.

Pre-filled lubricant cartridges are available as accessories.

Intended Use

Intended use of the FP4 N411A is to supply one lubrication point with grease or highly viscous oil.

Technical Data

Power supply	+24 VDC +/-10%	
Number of outlets	1	
Operating temperature	min.	- 20° C
	max.	+ 60° C
Maximum output pressure	70 bar	
Protection class	IP 54	
Volume per dispensing stroke	0,15 ml	
Lubricants	Grease	up to NLGI Klasse 2
	Oil	up to 30.000 mm ² /s (40°C)
Cartridge volume	400 ml	
Outlet connection	Connector for hose 6 mm	
Mounting position	any	
Weight (without cartridge)	1040 g	

Important instructions

To ensure trouble-free operation on the FP4 N411A, do not disassemble the unit. To prevent damage to the electronics, only original battery packs must be used.

A detailed description of the operation and control of the FP4 N411A is available in the up-to-date user manual!



Figure 1: FP4 N411A front view



Figure 2: FP4 N411A with 400 ml

Electrical Connection

Connector Type	M12x1, 4-pole, A-coding
Pin assignments	PIN 1 Input +24 VDC +/- 10% max. current consumption 0,3 A
	PIN 2 Pump control +24VDC +/- 10%
	PIN 3 Ground (GND)
V Output Signal = V Input Signal	PIN 4 Output signal, +24 VDC +/- 10% max. current capacity 0,1 A, short-circuit protected, No inductive load

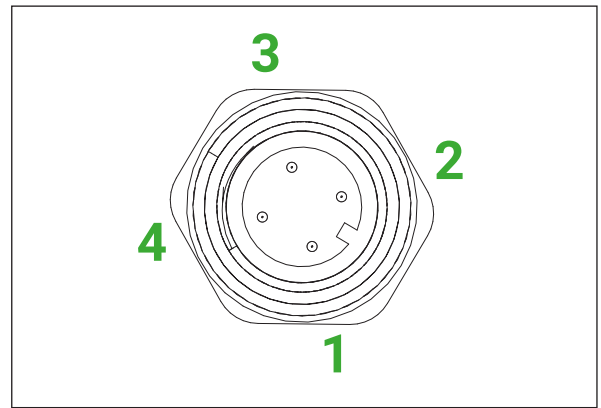

Operating mode Hour mode (-h-)

The hour mode -h- allows setting the number of dispensing strokes (c) and a pause time (h) between two dispensing cycles in hours. Pause times (h) between 1...240 hour(s) and the number of dispensing strokes (c) between 1...30 can be set. Therefore, a dispensing cycle consists of up to 30 dispensing strokes. The FP4 N411A delivers the set number of dispensing strokes after the pause time has elapsed.

Default settings Hour mode (-h-)

Pause time: h = 3 hours

Number of strokes: c = 1

Operating mode Emptying time (Et)

The emptying time mode Et allows setting the number of dispensing strokes (c) and the emptying time of the cartridge in months. Emptying times between 1...36 month(s) and the number of strokes (c) between 1...30 can be set. Therefore, a dispensing cycle consists of up to 30 dispensing strokes. The FP4 N411A calculates a pause time and delivers a dispensing stroke after the pause time has elapsed.

Default settings Emptying time (Et)

Emptying time: Et = 6 months

Number of strokes: c = 1

Display – Meaning of LEDs

LCD	Explanation
	The red LED flashes every 5 seconds if there is an error.
	The yellow LED lights up when the action area has been touched with the magnetic pen (magnetic pen detected).
	The green LED lights up for approx. 10 ... 18 seconds during a dispensing process.
	The green LED flashes every 5 seconds if the FP4 N411A is switched on (ON) and there is no error.
	The yellow LED flashes every 5 seconds, when the pre-warning limit of the cartridge is reached.

Error messages on the display

Error messages	Meaning
E1	Error E1 (empty cartridge)
E2	Error E2 (overload)
E3	Error E3 (undervoltage)
E4	Error E4 (internal device error)

Commands for control

The commands explained below can be called up at any time in operating mode -h- and in operating mode Et.

Command	Explanation
INF	The INF command provides an informative overview of the current settings on the FP4 N411A.
SET	The SET command allows you to make changes to the operating mode.
RUN	The RUN command enables a single dispensing to be triggered manually on the FP4 N411A.
PRO	The PRO command allows you to make changes to the settings and dispensing action of the FP4 N411A.
FIL	The FIL command allows you to manually trigger 40 dispensing action of the FP4 N411A.

Operating mode Pulse mode (PUL)

In the pulse mode PUL, the FP4 N411A can be operated and controlled by an external control system such as a PLC unit. The FP4 N411A ensures the delivery of one or more dispensing stroke(s) depending on the control signals from the external controller.

Control via PIN 2

Software version	N41
Signal length 2s	1 Dispensing stroke (1.1)
Signal length 12s	40 Dispensing strokes
Signal length 14s	Acknowledgement of errors, interruption of lubricant supply

Output Signals at PIN 4

Operation readiness – HIGH level

The FP4 N411A sends a permanent output signal (HIGH level) to PIN 4, which indicates that it is ready for operation. The output signal at PIN 4 can be tapped for further processing (e.g., LED or as a level for an external control).

Feedback Signal (only in PUL mode)

After successful activation, the FP4 N411A sends a LOW level output signal to the external controller as confirmation for the duration of the motor running (ML). After the end of an error-free dispensing stroke, the output signal on the FP4 N411A changes back to a HIGH level. If the filling level of the cartridge falls below approx. 24 cm³, the pump control extends the LOW level to 17s regardless of the engine running. This signal is defined as a pre-warning signal (VWS) for predictive level monitoring.

Error Signal – LOW level

If there is an error, the FP4 N411A sends continuous LOW level output signal for more than 30s at PIN 4. This is not the error signal for an empty cartridge!

Empty Cartridge Signal – Square wave signal, f = 0,5 Hz

The FP4 N411A is equipped with a sensor that determine when the lubricant cartridge is empty. The empty cartridge report is transmitted to the external controller. A separate, unique output signal is provided which can be easily recognized by the external controller.

Hint Pulse mode (PUL)

Make sure that your control program is correctly selected for your application and that the lubrication point is supplied with the right amount of lubricant per unit of time.

Example: Control signal 2 seconds

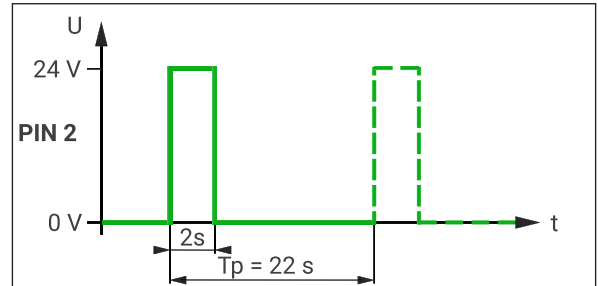

Tp = pause time between two control signals (see user manual for description)

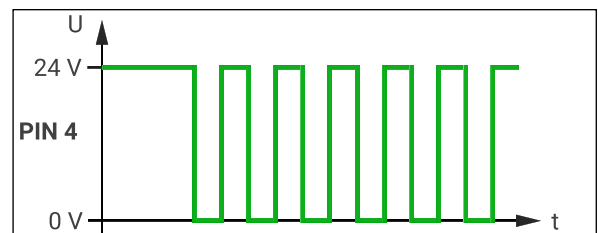
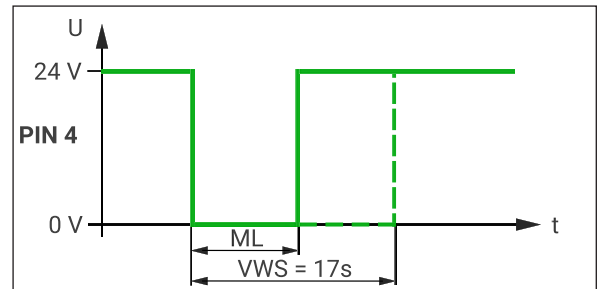
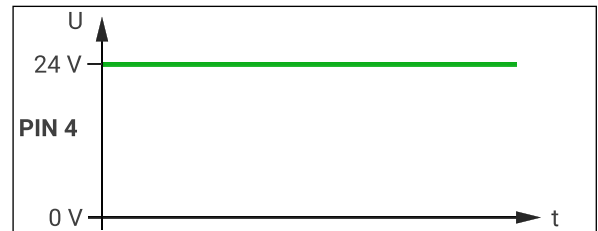

Installation dimensions

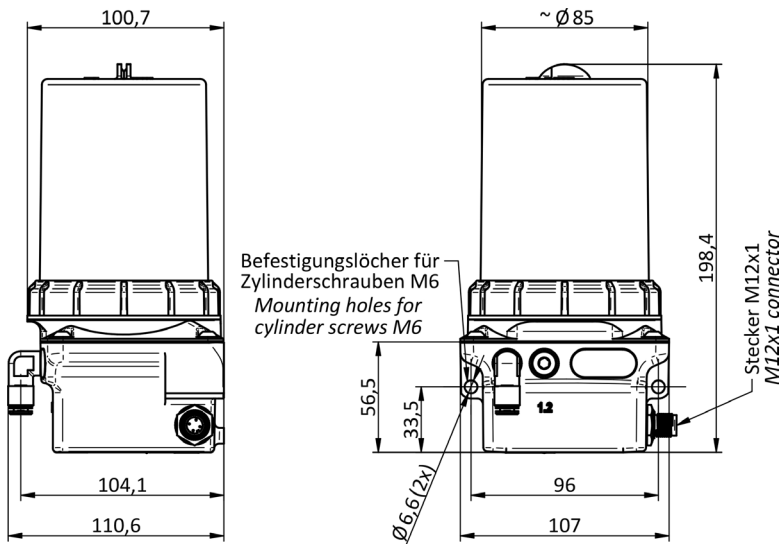

Installation

When installing, allow a minimum of 370 mm clearance from the top of the pump in opening direction of the cartridge for easy replacement.

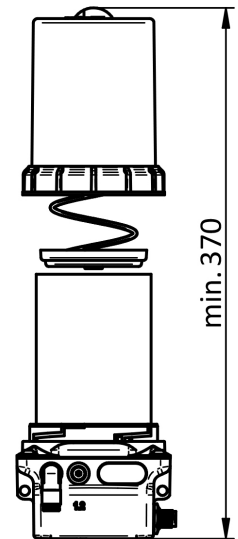

Materials

Housing of drive unit	Die-cast zinc, powder-coated
Transparent top	Polyamide (impact-resistant, lubricant-resistant, UV-stable)
Drive unit cover	Polyamide 6.6, glass fiber reinforced
Screws	Stainless steel A2
Hose connector	Brass, nickel-plated
Grease cartridge	Polypropylene, polyethylene
Compression plate	Polyamide 6.6 (impact-resistant, lubricant-resistant)
Compression spring	Stainless spring steel

Similar products

Description	Difference	Item-Nr.
FlexxPump4 N211A	Cartridge 250 ml, anthracite	210964
FlexxPump4 N411	Cartridge 400 ml, green	210958
FlexxPump4 N211	Cartridge 250 ml, green	210962
FlexxPump4 N411-OIL	Oil as lubricant, green	210966
FlexxPump4 N411A-OIL	Oil as lubricant, anthracite	210968

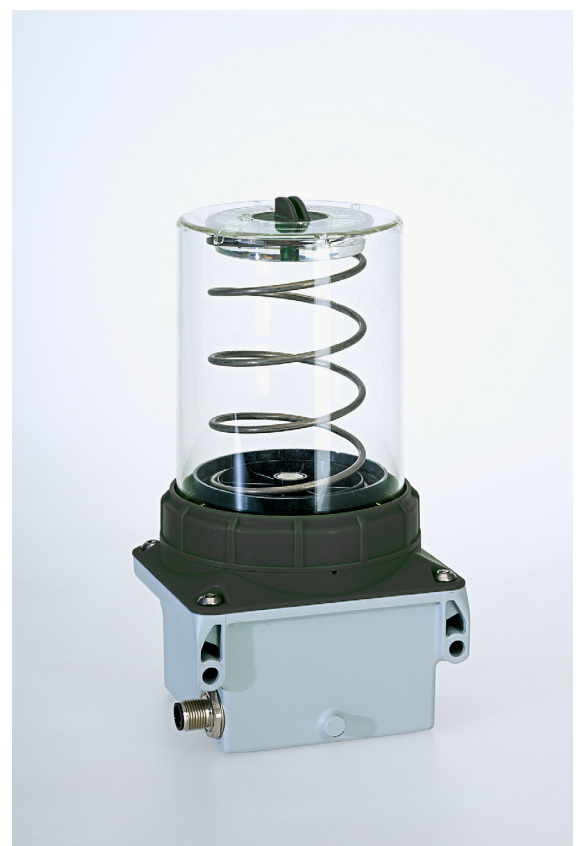

Figure 3: FP4 N411A back

Please visit www.triboserv.com for available Accessories

The above data and information correspond to the current state of our knowledge and development. However, they do not represent an assurance of properties or a guarantee for the suitability of the products in individual cases. We reserve the right to change the information in this technical data sheet or to make technical changes at any time and without prior notice. The representation on the pictures may differ from the original.

TriboServ

SpectroLube Inc.
President: Aykut Ozdemir

2212 Silverbirch Court
L7M 3H4 Burlington, Ontario
Canada

Phone: +1 (647) 278-4366
Mail: aykut.ozdemir@spectrolube.com
Web: www.spectrolube.com



Quality Management

We are certified.

ISO 9001:2015

© – 2021

EN
Version: 1.0
Page 4 of 4